

MUST BE FITTED BY PROFESSIONAL

AARTONMOUNTS

LCD BRACKET NUMBER 3016F BLACK LARGE

1. Parts List

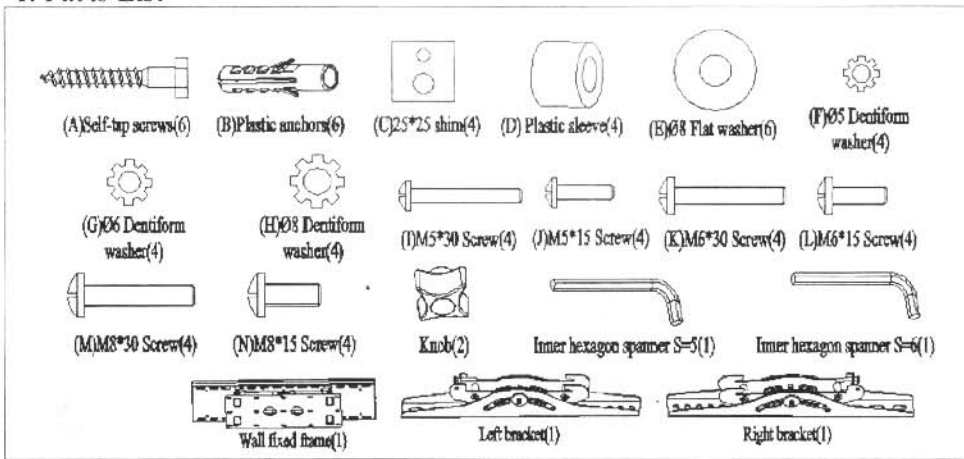

2. Name of parts

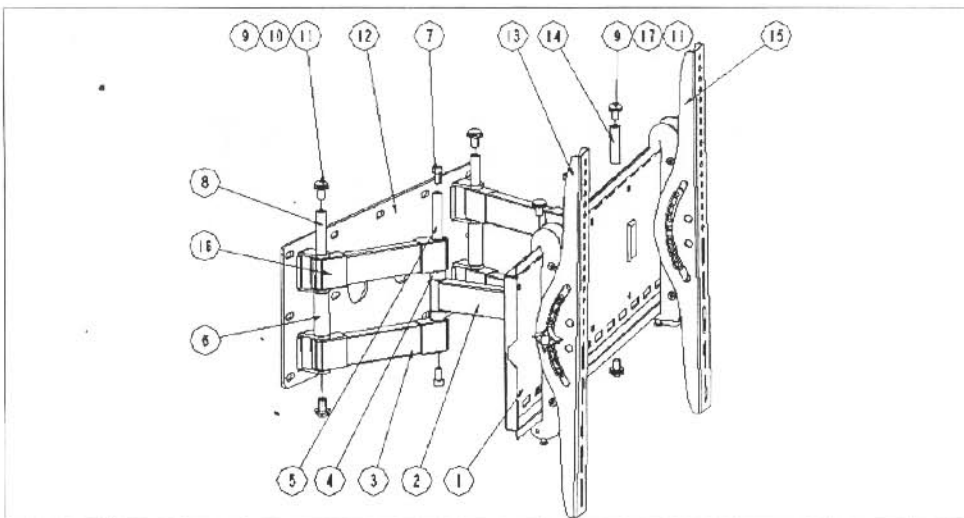

Item NO.	Symbol	Name	Material	Quantity	Remark
1	3016FL-01-0	movable panel	welding part	1	
2	3016F-02-0	turnning arm welding part	welding part	2	
3	3016F-03-0	supporting tube welding part	welding part	4	
4	3016F-04	small sleeve	Q235	4	
5	3016F-05	inner thread axis(middle)	Q235	2	
6	3016F-06	supporting sleeve	Q235	2	
7	M8*15	inner hexagon bolt	Standard part	4	
8	3016F-07	inner thread axis(long)	Q235	2	
9	M8*15	inner hexagon bolt with half round head	Standard part	8	
10	φ 8	spring washer	Standard part	4	
11	φ 8	washer	Standard part	8	
12	3016F-08-0	wall fixed plate	welding part	1	
13	3016FL-09	fixed pothook(left)	assembled part	1	
14	3016F-10	inner thread axis(short)	Q235	2	
15	3016FL-11	fixed pothook(right)	assembled part	1	
16	3016F-12	plastic cover	RPVC	12	
17	3016F-13	attrition washer	copperplate	4	

3. Note:

Step 1:
Drill 6 holes of Φ10 and 50mm deep at a suitable height on the concrete wall and insert 6 plastic anchors into the holes. You may use the Wall fixed frame as a templet to determine the position to drill the holes. Please refer to a qualified professional for mounting to other material walls.

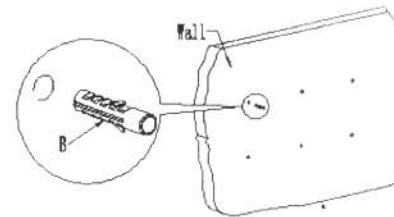

Step 2:
Referring to the sketch map, get 6 self-tapping screws A through the M8 flat washer E and the mounting hole on the wall dead plate to screw into the plastic anchors to fix the Wall fixed frame on the wall.

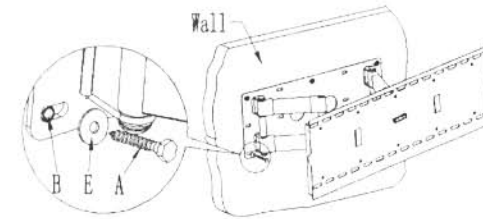

Step 3:
Select suitable screws and corresponding flat washers and dentiform washers according to the TV size and thread holes' diameter. Use 4 screws to mount the left hanging bracket and the right hanging bracket to the back of the display. When mounting the brackets, please insure that the side of the brackets, which provided with the hooks, should be towards the top of the display with the mounting holes kept concurrent, and use the center-positioned holes as possible. the knobs are mounted on the center screws on the bracket, and they are towards outside of the display to adjust the degree of tightness with hand easily.

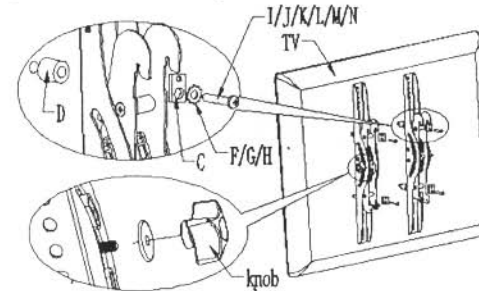

Step 4:
It needs two persons to lift the flat panel TV to hang it to the wall dead plate through the left and right hanging brackets. Don't loosen hands until the display has been hung firmly with the brackets.

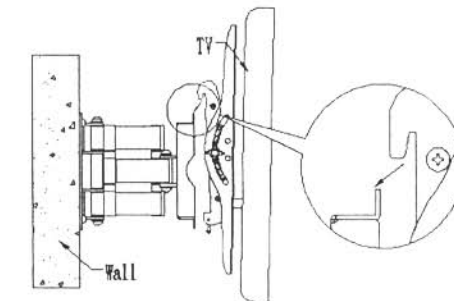

Step 5:
There is a bolt under both of the left and right brackets, screw out a majority of the bolts before mounting, and re-screw down them to against closely to the wall plate after the brackets have been hung firmly. The knobs must be loosened before adjusting the viewing angle for the flat panel TV between ±10°. After the angle has been adjusted, the knobs must be screwed down furthest.

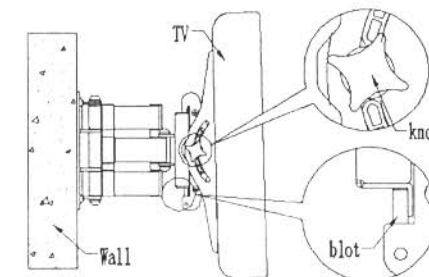

4. Notes

- (1) The wall plate should be fixed on a solid concrete wall
- (2) Must Be Fitted By A Professional.