

AARTONMOUNTS 3951

To be fitted by professional only

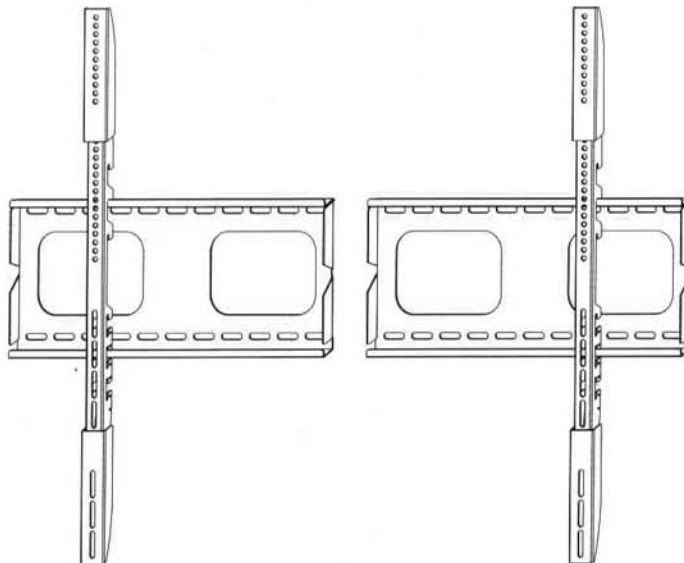

UNPACKING INSTRUCTIONS

- Carefully open the carton, remove contents and lay out on cardboard or other protective surface to avoid damage.
- Check package contents against the Supplied Parts List in the next page to assure that all components were received undamaged. Do not use damaged or defective parts.
- Carefully read all instructions before attempting installation.

IMPORTANT SAFETY INFORMATION

Install and operate this device with care. Please read this instruction before beginning the installation, and carefully follow all instructions contained herein. Use proper safety equipment during installation.

Do not use this product for any purpose or in any configuration not explicitly specified in this instruction. We hereby disclaims any and all liability for injury or damage arising from incorrect assembly, incorrect mounting, or incorrect use of this product.



WARNING

CAUTION!

This mount must be fitted to a vertical concrete wall or vertical solid wooden wall.

Supplied Parts List

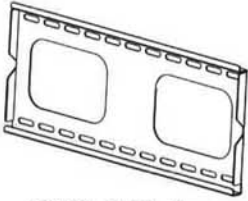

(2)Wall Plate-a

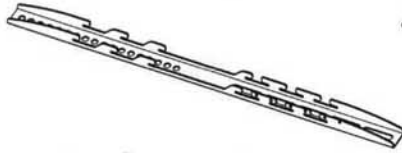

(1)Left Monitor Bracket-b



(1)Right Monitor Bracket-c



(2)Locking Bar-d

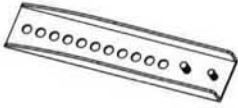

(2)Bracket Top Ext.-e



(2)Bracket Bottom Ext.-f

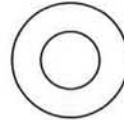

(8)Metal Washer-g



(8)Flange Nut-h



(4)M4x12 Bolt-i



(4)M5x12 Bolt-j



(4)M6x12 Bolt-k



(4)M8x16 Bolt-l



(4)M4x30 Bolt-m



(4)M5x30 Bolt-n



(4)M6x35 Bolt-o



(4)M8x40 Bolt-p



(4)M4 Lock Washer-q



(4)M5 Lock Washer-r



(4)M6 Lock Washer-s

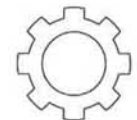

(4)M8 Lock Washer-t

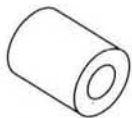

(4)M4/M5 Space-u

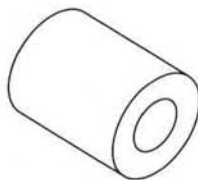

(4)M6/M8 Space-v

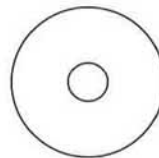

(8)M4/M5 Washer-w

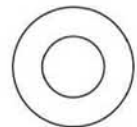

(4)M6/M8 Washer-x



(2)Safety Bolt-y



(8)Lag Bolt-z

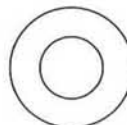

(8)Lag Bolt Washer-aa

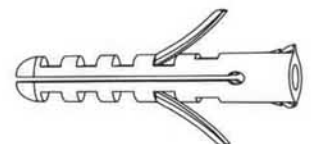

(8)Concrete Anchor-bb

Step 1

Diagram 1

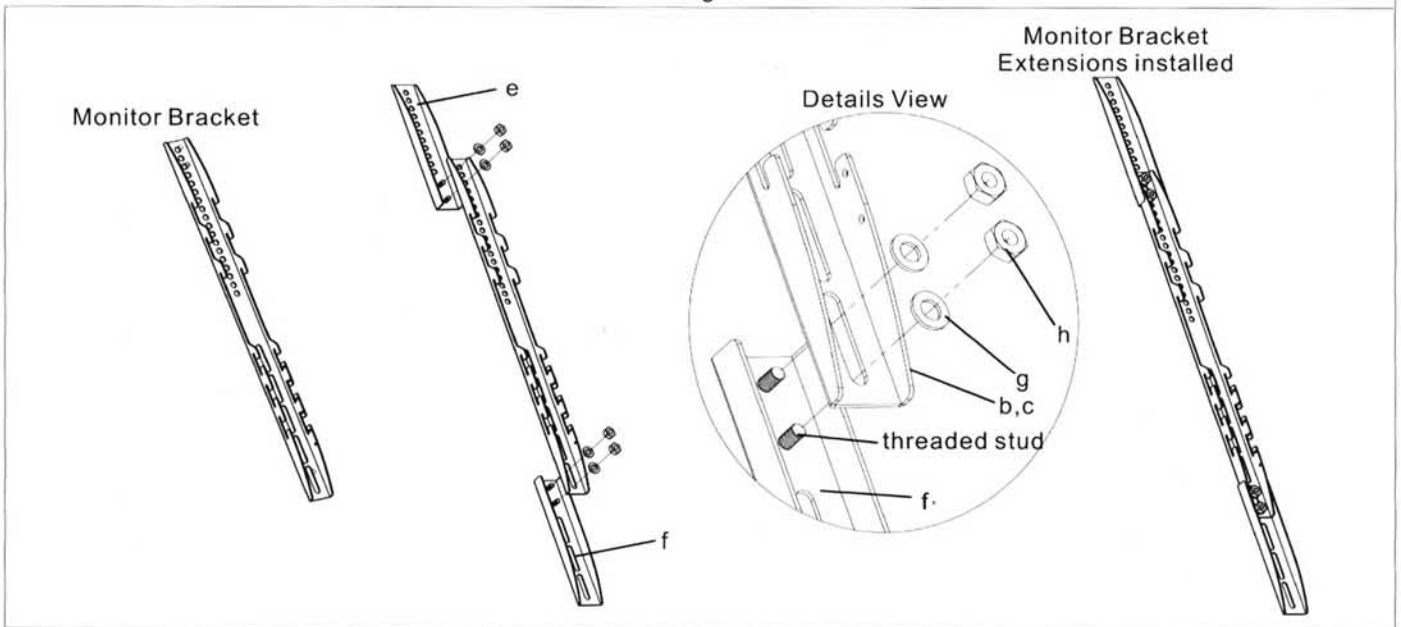

Step 2A

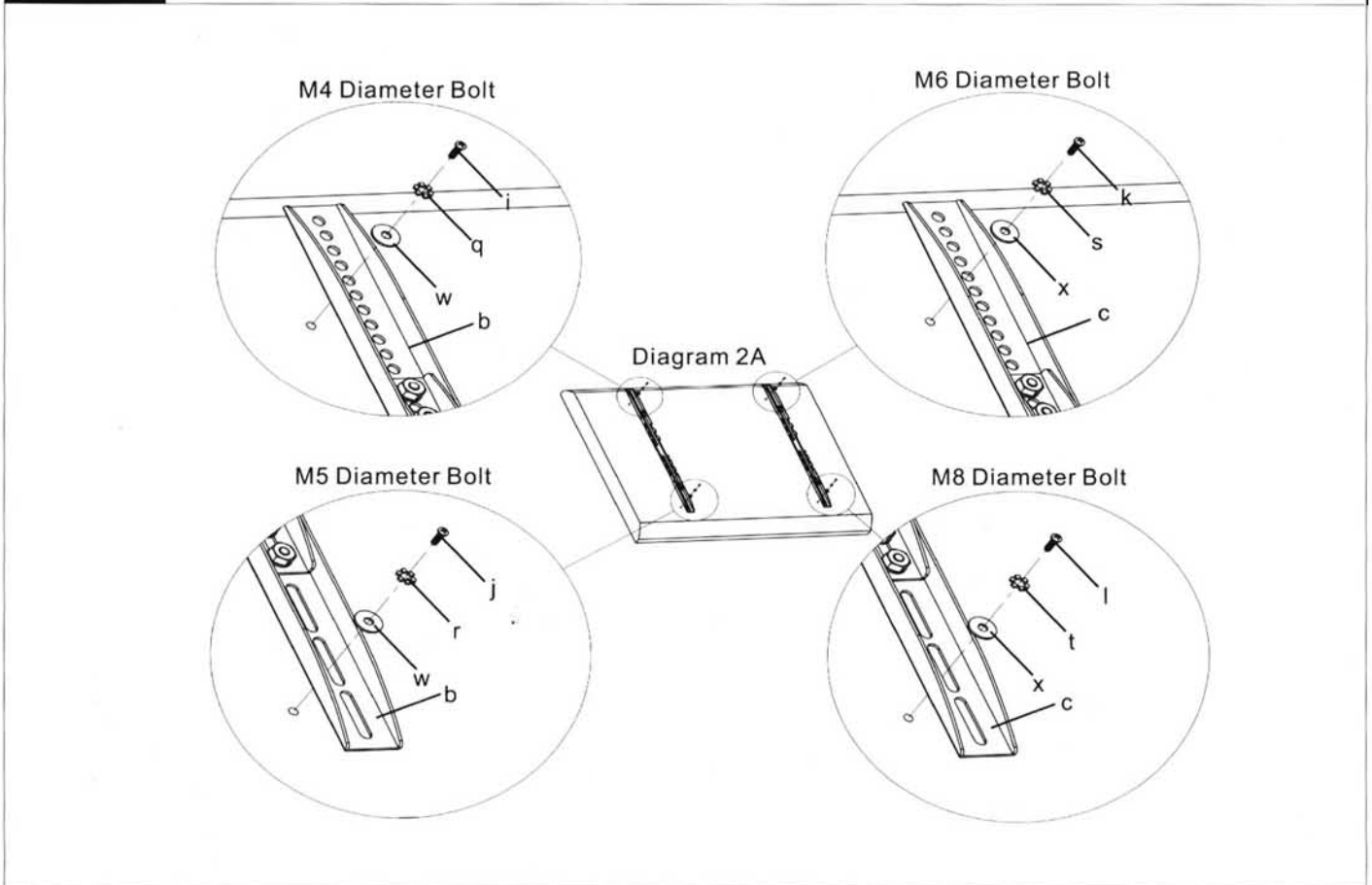

Step 2B

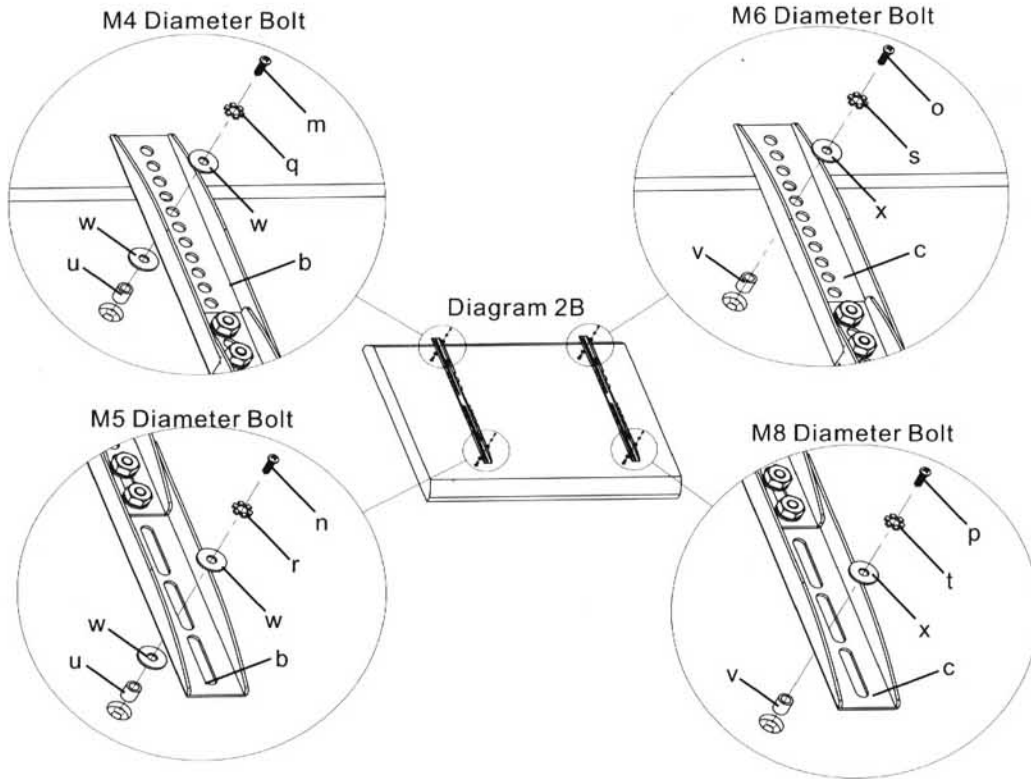

Step 3

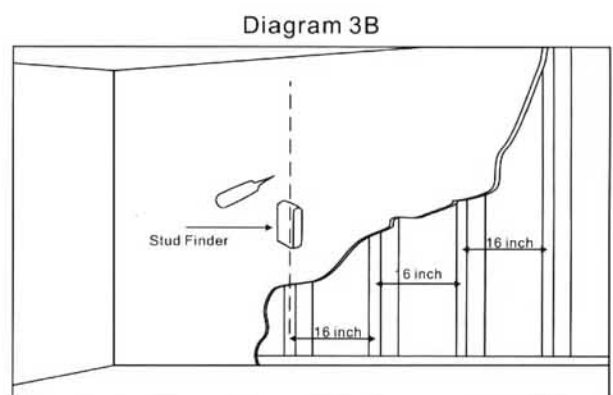
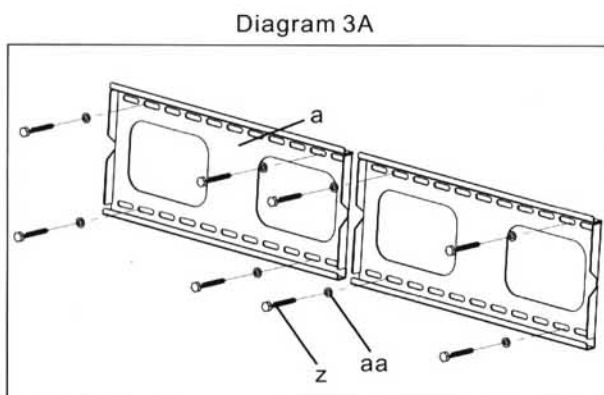

Step 4

Diagram 4A

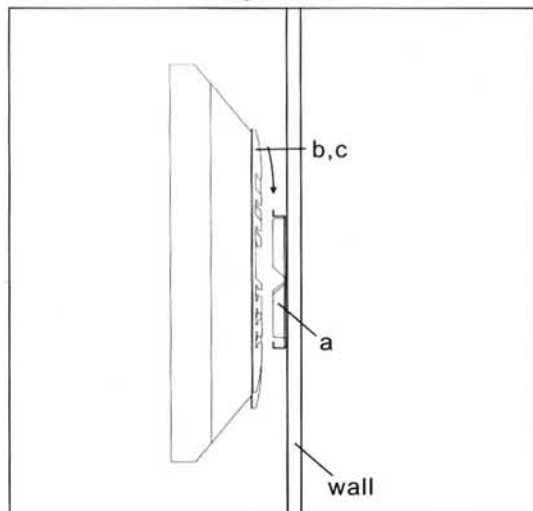
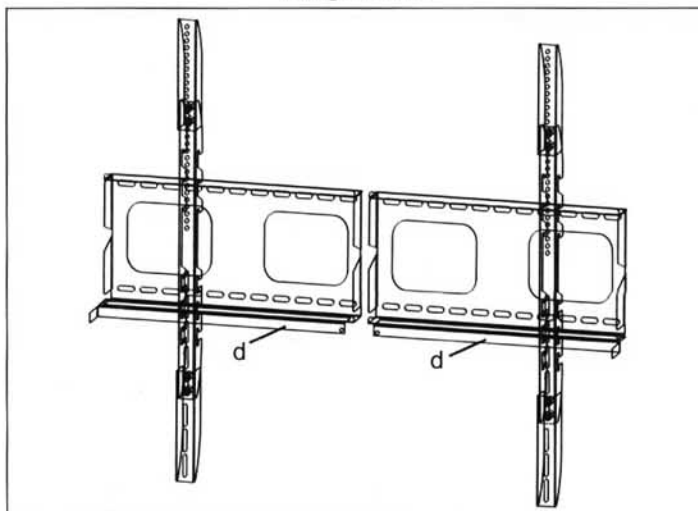

Diagram 4B



Thanks for choosing our products, enjoy the using.