

MUST BE FITTED BY PROFESSIONAL
AARTONMOUNTS
LCD BRACKET NUMBER 3029F

1. Parts List

No.	Name of part	Material	Amount
A	Self-tap screw	Standard part	6
B	Plastic anchor	Standard part	6
C	25*25 Shim	Q215	4
D	Plastic sleeve	PA	4
E	Ø8 Flat washer	Standard part	6
F	Ø5 Dentiform washer	Standard part	4
G	Ø6 Dentiform washer	Standard part	4
H	Ø8 Dentiform washer	Standard part	4
I	M5*30 Phillips screw	Standard part	4
J	M5*15 Phillips screw	Standard part	4
K	M6*30 Phillips screw	Standard part	4
L	M6*15 Phillips screw	Standard part	4
M	M8*30 Phillips screw	Standard part	4
N	M8*15 Phillips screw	Standard part	4
	Wall plate	Q215	1
	Monitor bracket	Jointing part	2
	Lock pole	Jointing part	1

2. Name of parts

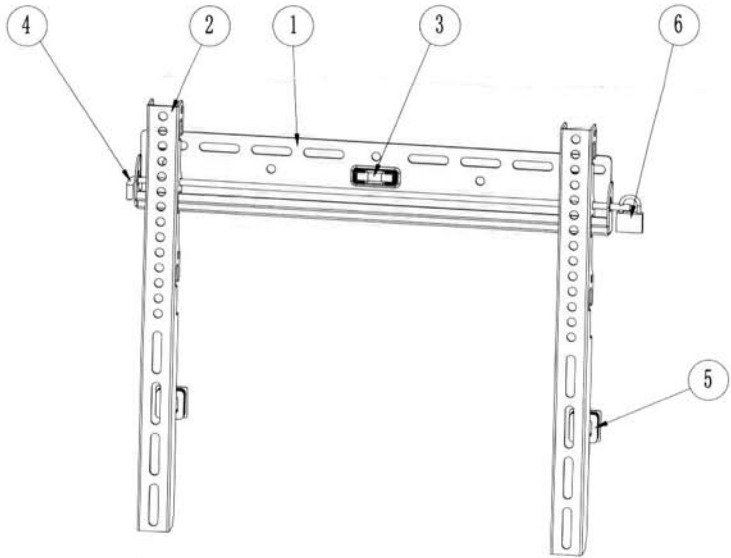

Item NO.	Name	Material	Amount	Remark
1	Wall plate	Q215	1	δ=2
2	Monitor bracket	Q215	2	δ=2
3	Bubble level	Standard part	1	δ=2
4	Lock pole	Q235	1	
5	Plastic pads	PP	2	
6	Lock	Standard part	1	Not included

3.

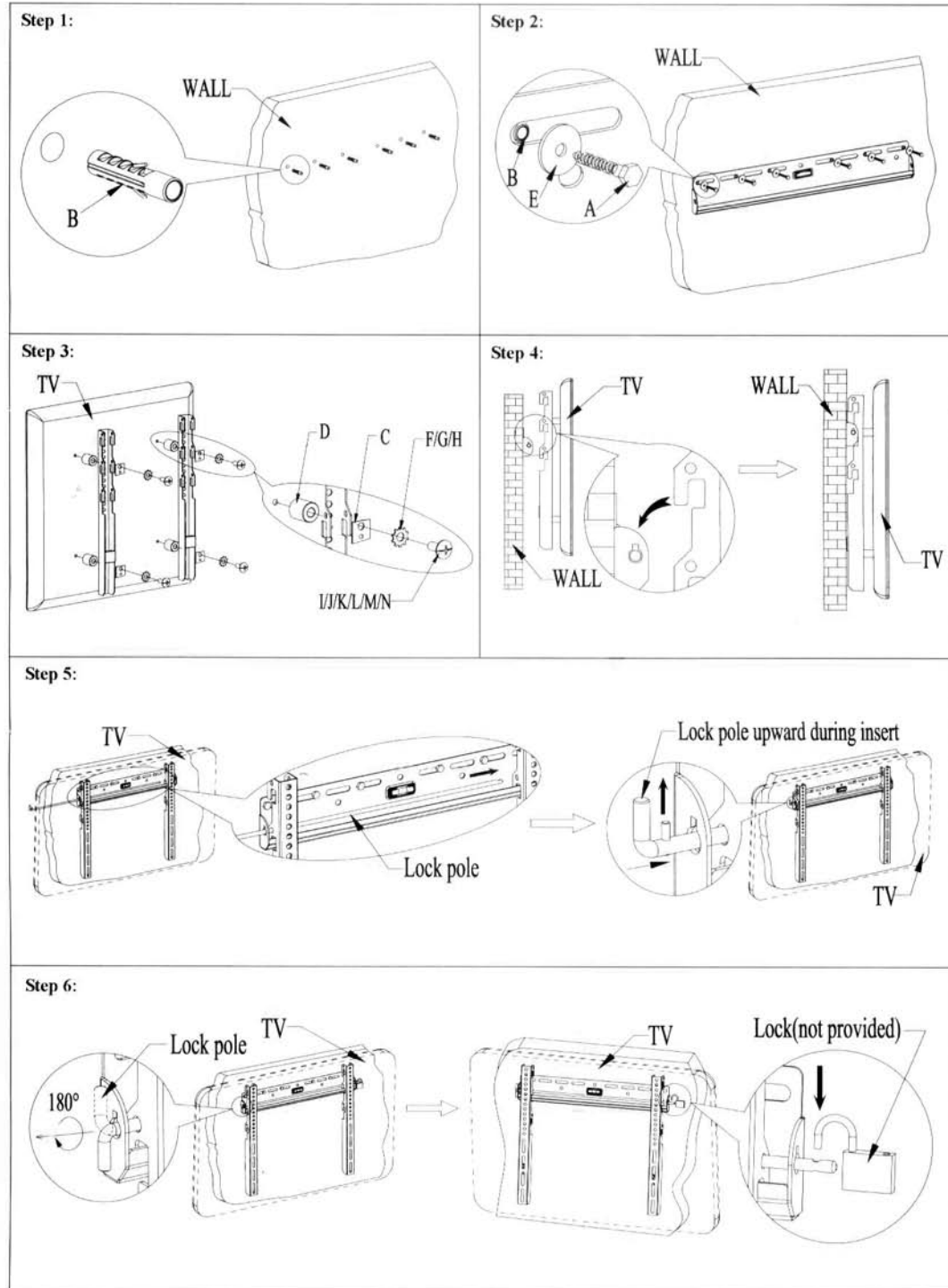

Must Be Fitted By A Professional.