

**MUST BE FITTED BY PROFESSIONAL  
AARTONMOUNTS  
LCD BRACKET NUMBER 3003F**

**1. Parts List**

No.	Name of part	Material	Amount
A	Lag bolt	Standard part	6
B	Plastic anchor	Standard part	6
C	25*25 shim	Standard part	4
D	Plastic sleeve	PA	4
E	Ø8 Flat washer	Standard part	6
F	Ø5 Lock washer	Standard part	4
G	Ø6 Lock washer	Standard part	4
H	Ø8 Lock washer	Standard part	4
I	M5*30 Phillips screw	Standard part	4
J	M5*15 Phillips screw	Standard part	4
K	M6*30 Phillips screw	Standard part	4
L	M6*15 Phillips screw	Standard part	4
M	M8*30 Phillips screw	Standard part	4
N	M8*15 Phillips screw	Standard part	4
	Wall plate	Q215	1
	Monitor bracket	Q215	2

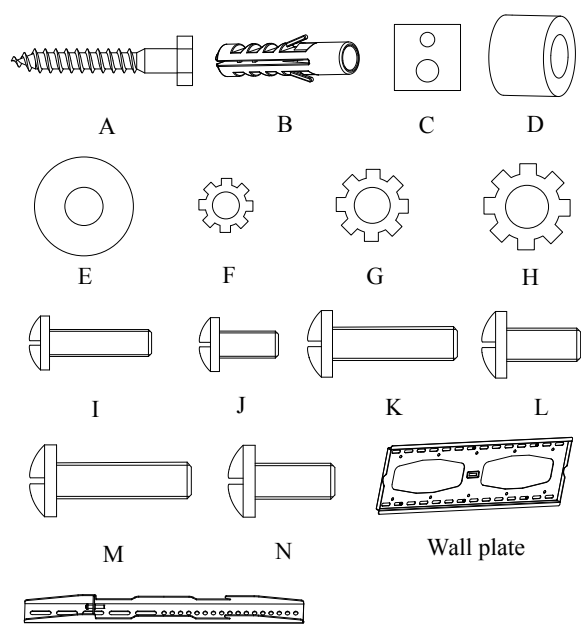

**2. Name of parts**

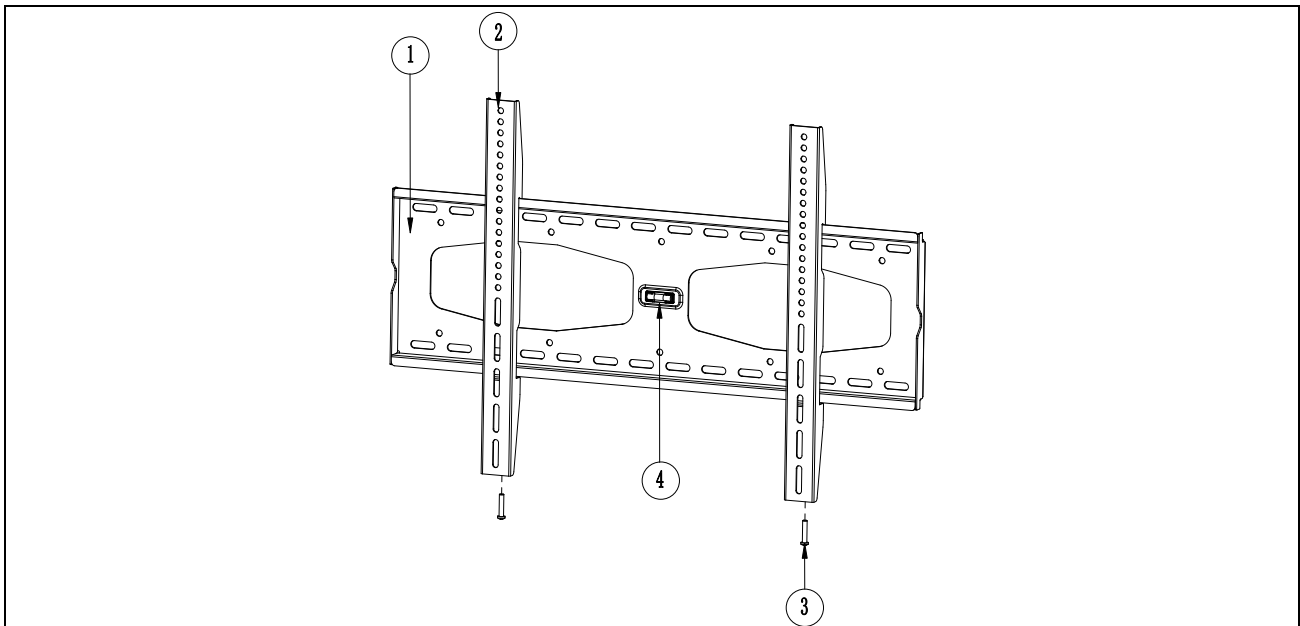

Item NO.	Name of part	Material	Amount	Remark
1	Wall Plate	Q215	1	δ=2
2	Monitor Bracket	Q215	2	δ=2
3	Phillips screw	Standard part	2	
4	Bubble level	Assembled part	1	

3.

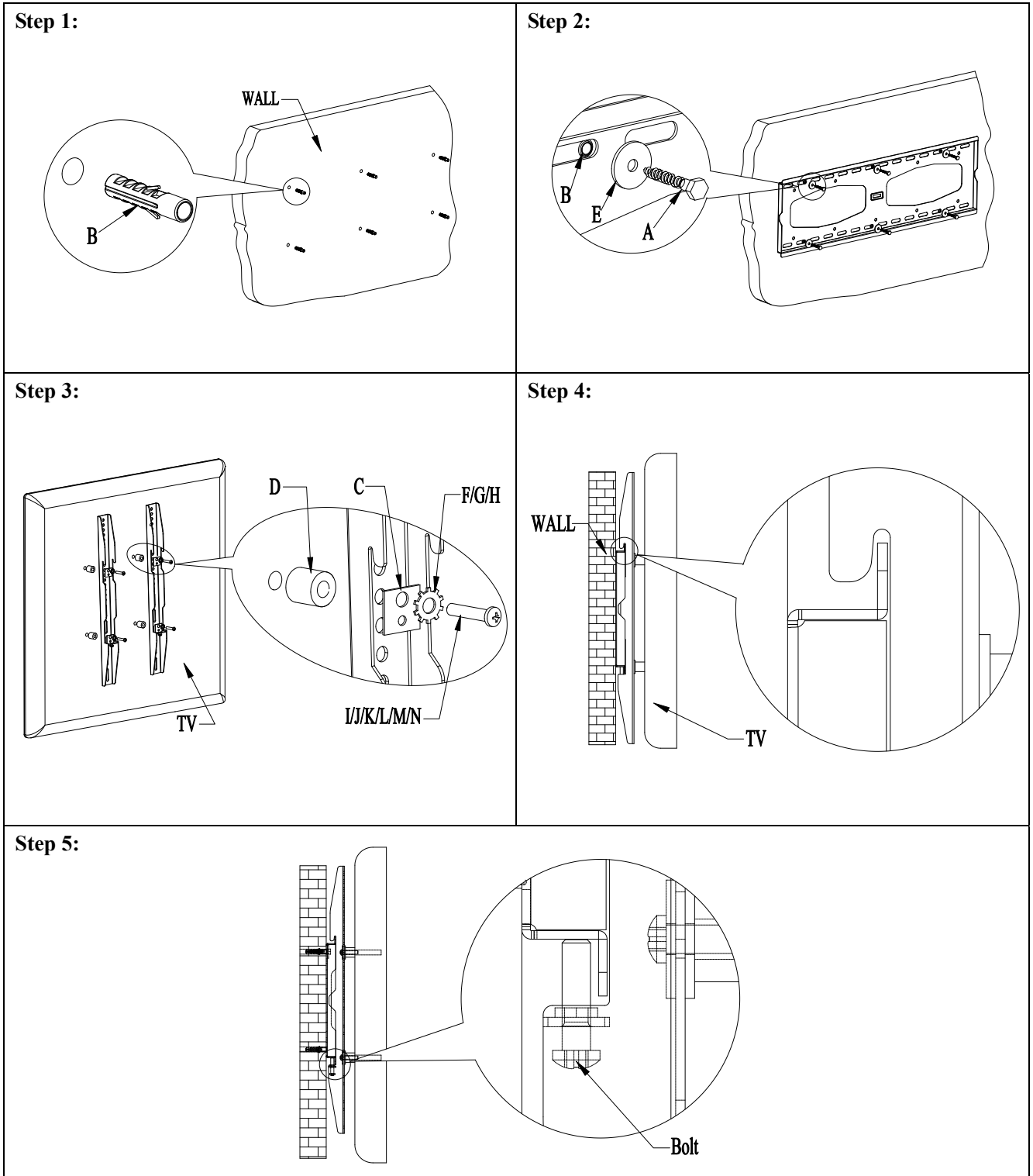

**Must Be Fitted By A Professional.**