

MUST BE FITTED BY PROFESSIONAL
AARTONMOUNTS
LCD BRACKET NUMBER 3004F

1. Parts List

No.	Name of part	Material	Amount
	Wall Plate	Q215	1
	Monitor Bracket	Jointing part	2
A	lag bolts	Standard part	6
B	plastic anchors	Standard part	6
C	25*25 shim	Standard part	4
D	M8 Spacer	Standard part	4
E	M8 washer	Standard part	6
F	M4 lock washer	Standard part	4
G	M5 lock washer	Standard part	4
H	M6 lock washer	Standard part	4
I	M4*30 Phillips screw	Standard part	4
J	M4*15 Phillips screw	Standard part	4
K	M5*30 Phillips screw	Standard part	4
L	M5*15 Phillips screw	Standard part	4
M	M6*30 Phillips screw	Standard part	4
N	M6*15 Phillips screw	Standard part	4

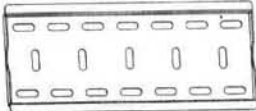

Wall Plate

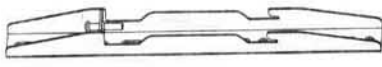

Monitor Bracket



A



B



C



D



E



F



G



H



I



J

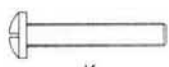

K



L

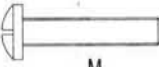

M



N

2. Name of parts

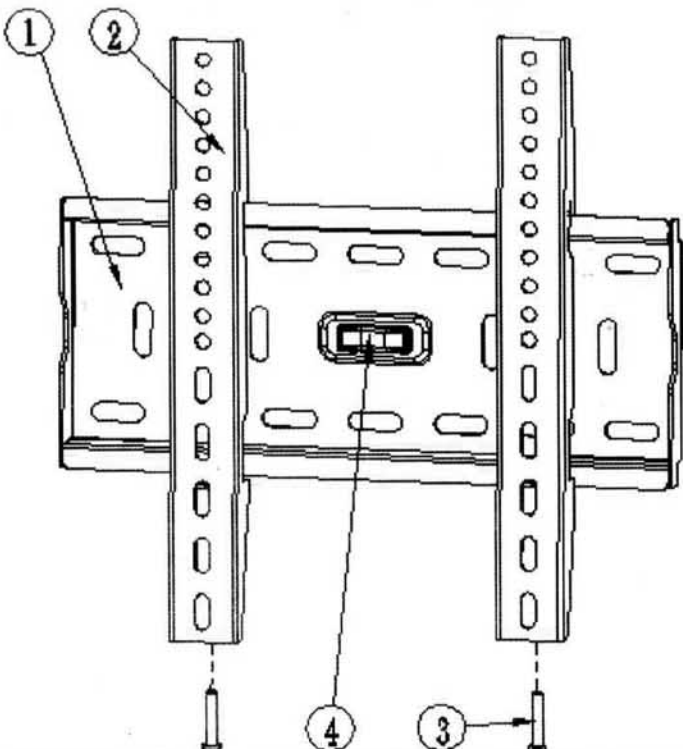

Item NO.	Symbol	Name of part	Material	Amount	Remark
1	3004F-01	Wall Plate	Q215	1	$\delta=2$
2	3004F-02	Monitor Bracket	Jointing part	2	
3	M6*30	Phillips screw	Standard part	2	
4	3004F-03	Gradienter	Assembled part	1	

3.

Step 1:

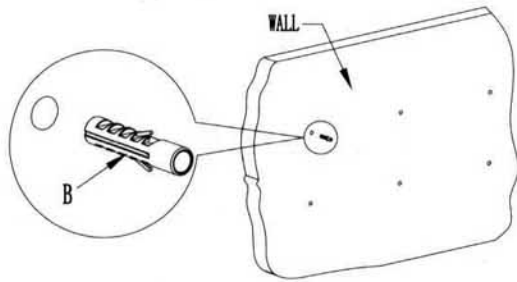

Step 2:

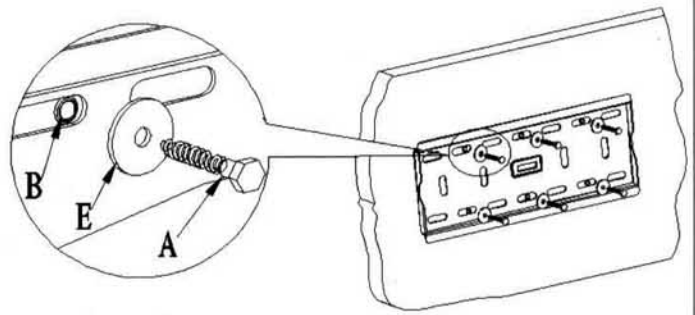

Step 3:

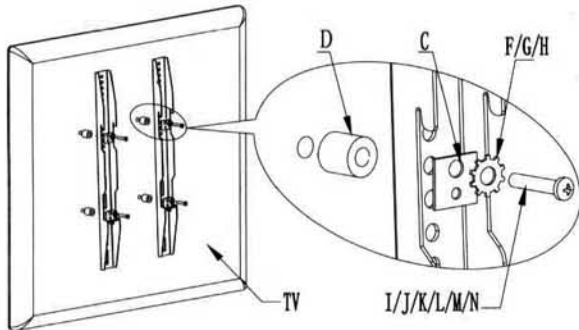

Step 4:

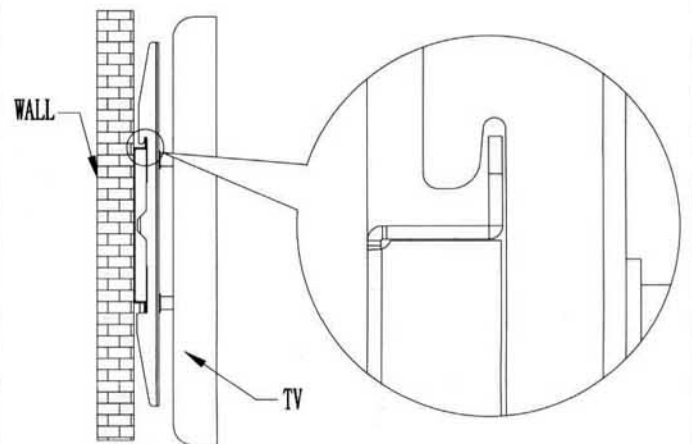

Step 5:

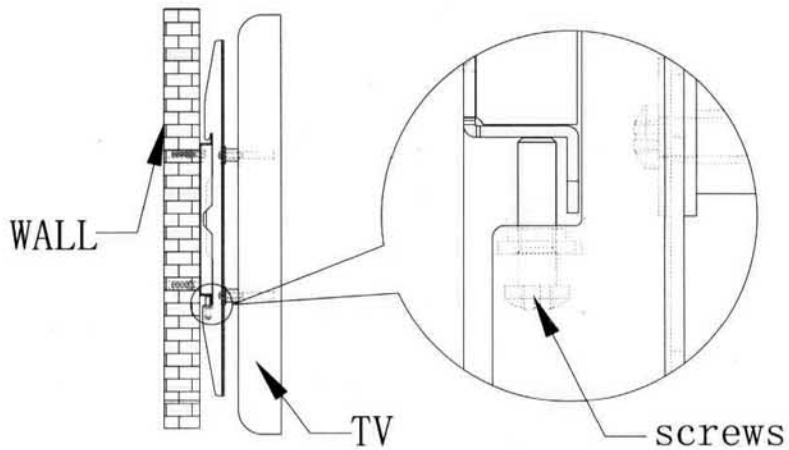

Must Be Fitted By A Professional.